

KH LIGHT TRACKS SYSTEM

KH-100, I, II-L, II Construction Tracks System and Components

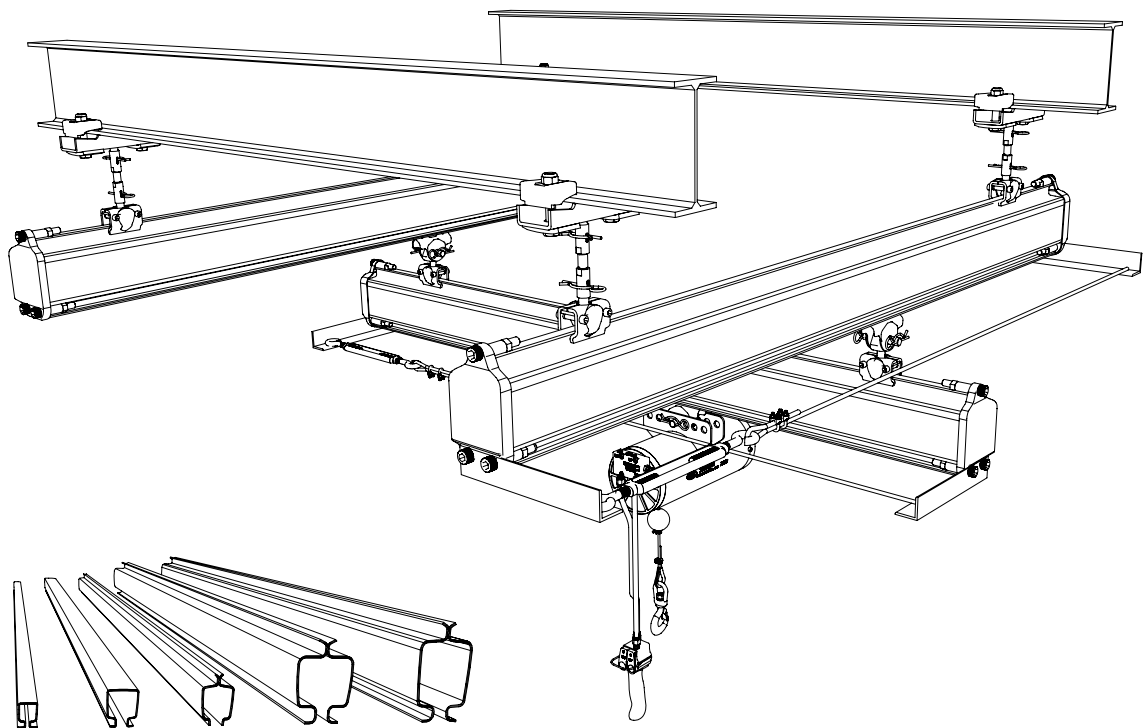

Contents

General	01
Single girder suspension crane	02
Double girder suspension crane	02
Monorail track	02
Diagram for crane and track selection	03
Structural dimensions for cranes and monorail tracks	04
1. Straight track section	05
1. KH-II-S Crane girder	05
2. Joint bolt set	06
4. Curved track section	06
6. Internal buffer stop	06
7. End cap with buffer	06
Upper suspension assembly	07
25. Upper suspension bracket	08
26. Upper suspension clamp	08
40. Ball head suspension rod	08
41. Suspension rod	09
42. Track suspension clamp	09
43. Spring clip	09
44. Ball head bolt	10
55. Trolley	10
57. Load bar	10
69. Trolley for friction wheel	11
70. Friction wheel travel drive	11
75. Crane suspension eye	11
78. Crab frame	12
79. Bracing Frame	12
83. Cable clamp	12
85. Cable slider	12
86. Cable trolley	13
Track suspension fittings	13

General

KH Light Tracks System installations are of modular design. The basic construction kit consists of simple, well engineered components. Standardized dimensions ensure rapid erection and allow existing installations to be easily modified or extended. All the components are batch-produced using modern series production machinery and methods.

Non-driving rail system for less cost and maintenance free for major components including trolley.

Trolley is totally protected by steel formed track.

Easy for expansion modification of Existing line.

Comfortable and easy for operation and noise free during traveling.

Offering flexibility against building obstruction.

Simple, fast and safe installation than conventional welding construction.

Standard fittings save cost, easy and fast dismantle for relocation. Reusable all parts.

Range of product 50~2,000kg depending on configuration. Curved track is another attractive advantage.

Suitable for building power supply, air supply system and transportation of various tools for assembly line application.

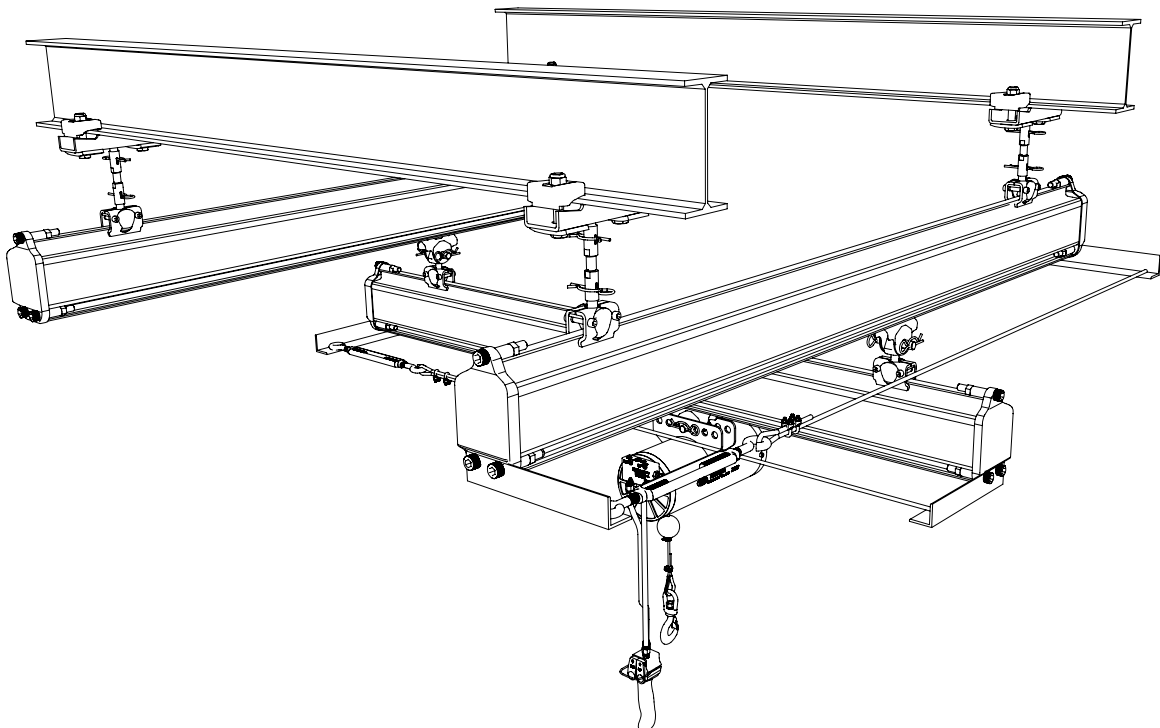

Single girder suspension crane

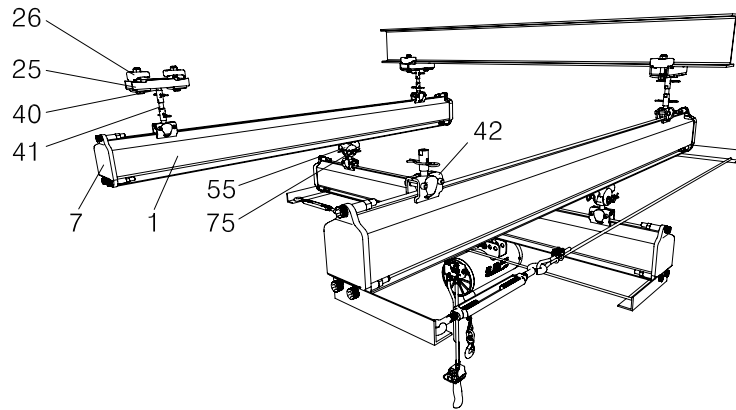

Double girder suspension crane

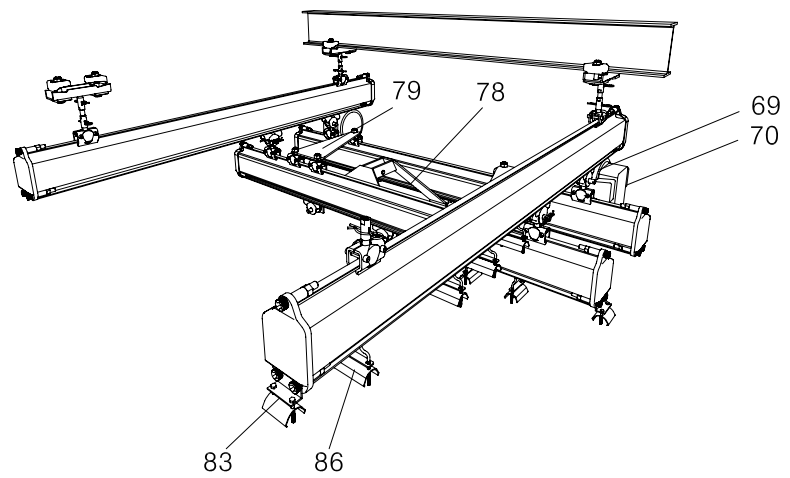

Monorail track

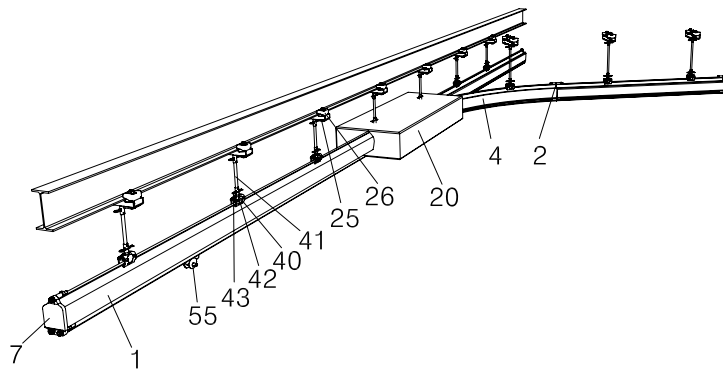

No.	Designation.	No.	Designation.	No.	Designation.
1	Straight track section	40	Ball head suspension rod	70	Friction wheel travel drive
2	Joint bolt set	41	Suspension rod	75	Crane suspension eye
4	Curved track section	42	Track suspension clamp	78	Crab frame
6	Internal buffer stop	43	Spring clip	79	Bracing frame
7	End cap with buffer	44	Ball head bolt	83	Cable clamp
20	Track switch	55	Trolley	85	Cable slider
25	Upper suspension bracket	57	Load bar	86	Cable trolley
26	Upper suspension clamp	69	Trolley for friction wheel		

Diagram for crane and track selection

Diagram: Spacing between supports, spans

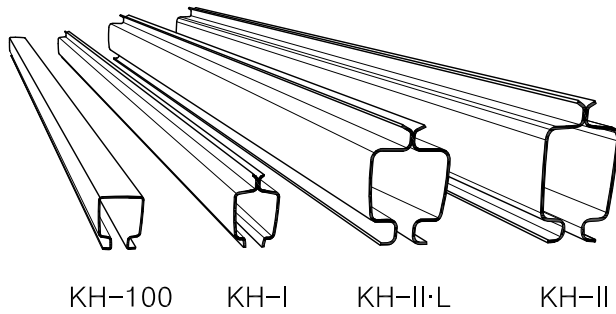

Section inertia moments:

KH-100 : 26 cm

KH-I : 80 cm

KH-II-L : 345 cm

KH-II : 660 cm

Neutral axis approx :

KH-100: 35 mm from lower edge

KH-I, II-L, II : section center line

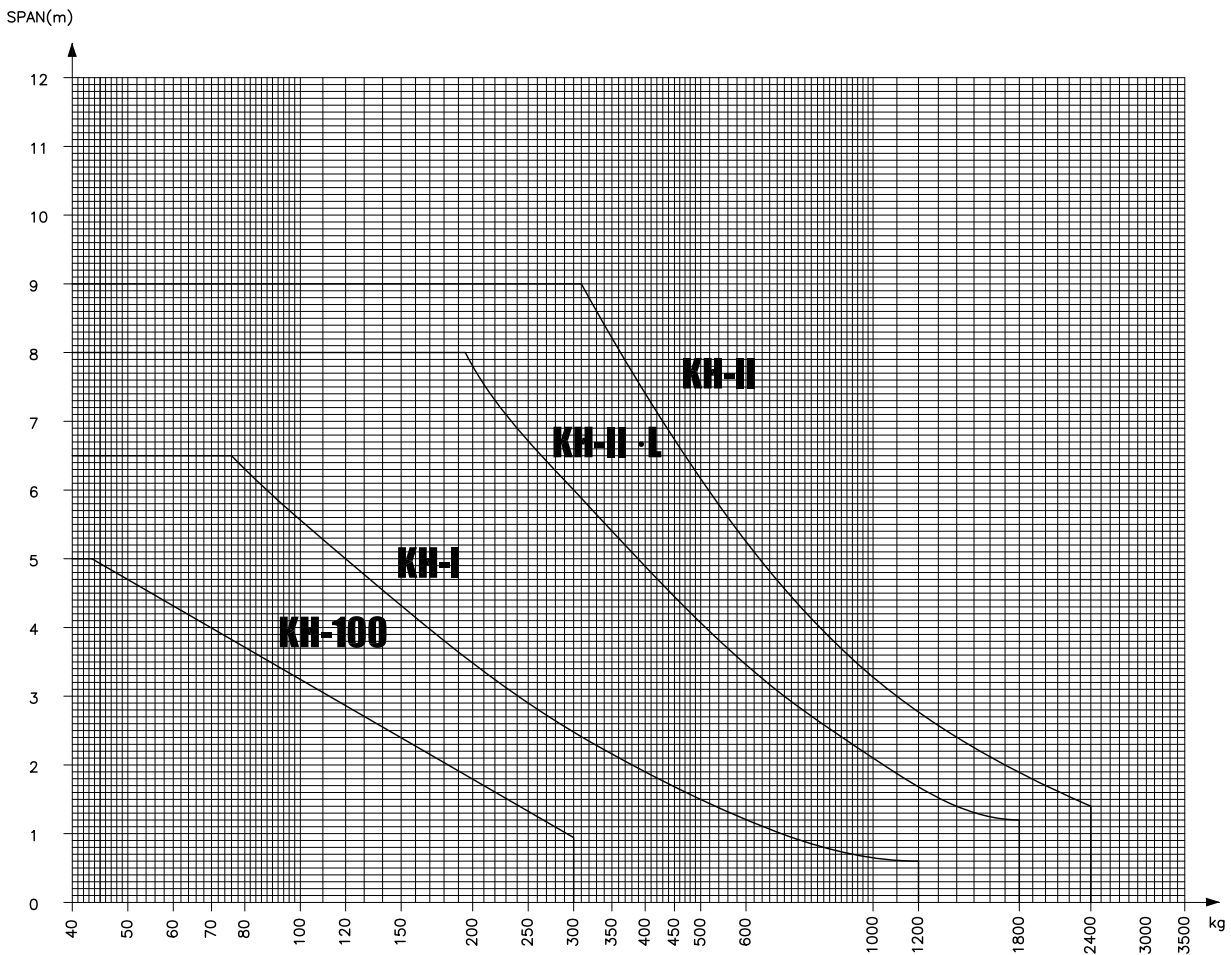

KH Track	Adjustable headroom dist. mm	Support distance span(m)	Load capacity (kg)						
			50	80	125	250	500	1000	1600
100	220		3.7	3.0	2.4				
I	250			5.0	4.1	2.5	1.5		
II-L	370				7.0	5.9	3.5		
II	400					7.0	5.4	3.2	

Structural dimensions for cranes and monorail tracks

Monorail track

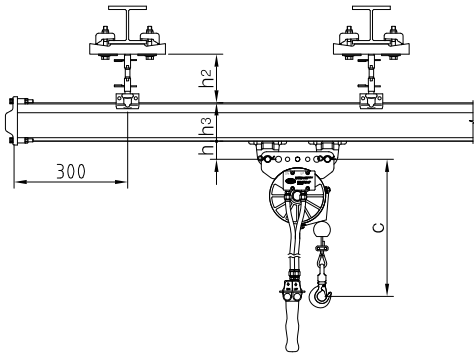

Single-girder crane

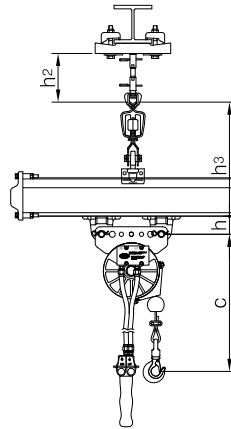

Double-girder crane

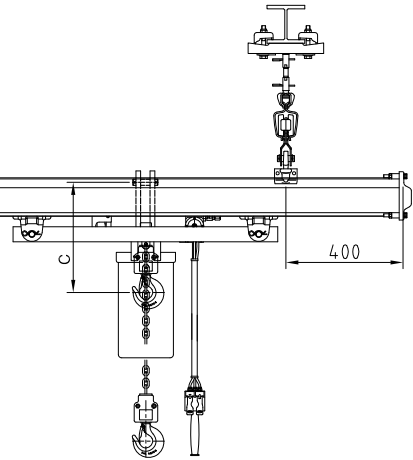

Structural dimension **h** mm (to center of pin)
Cranes and monorail tracks

KH-TRACK	100	I	II-L	II
h. mm	50	48	46	

Structural dimension **h2** mm
(Suspension from I-beam superstructure with upper suspension bracket)

KH-TRACK	Short suspension fitting	Length of suspension rod for spring clip				
		80	100	300	600	1000
100	104	162	-	382	682	1082
I	99	157	-	377	677	1077
II-L	142	-	249	449	749	1149
II	143	-	250	450	750	1150

Structural dimension **h3** mm

	Cranes												Single-track monorail							
	100				I				II-L				II				KH-Track			
KH-Track runway	100	I	II-L	II	100	I	II-L	II	100	I	II-L	II	100	I	II-L	II	100	I	II-L	II
KH-Track crane girder	100	I	II-L	II	100	I	II-L	II	100	I	II-L	II	100	I	II-L	II	100	I	II-L	II
single-girder	241	271	344	273	303	376	412	320	350	422	458	353	384	457	493	65	100	150	180	
Double-girder	251	281	354	283	313	386	422			437	473			472	508					

Structural dimension **C** mm

Model.	Air Hoist		Air balance									
		KA1S -025 & 050	KA1S -100	KAB -070 -200	KAB -100 -300	KAB -160 -200	KAB -R200 -150	KAB -R300 -100	KAB -T200 -300	KAB -T320 -200	KAB -TR400 -200	KAB -TR400 -150
C . mm	305	375	408	488	500	640	645	663	666	680	680	

1. Straight track section

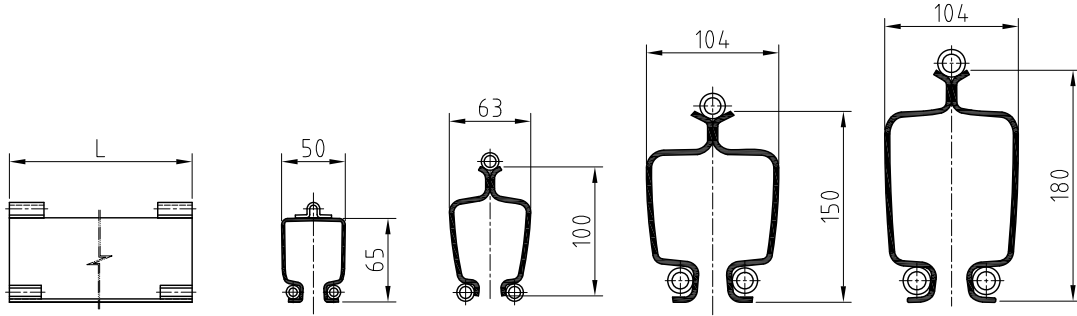
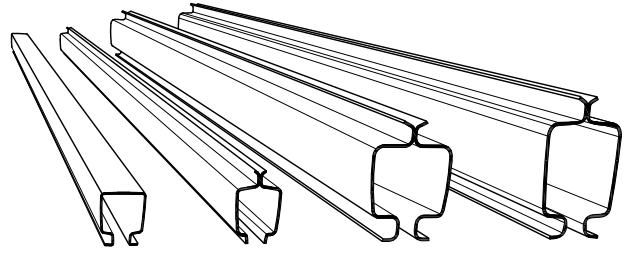

KH-100

KH-I

KH-II-L

KH-II

Length L	KH-100		KH-I		KH-II-L		KH-II	
	Weight appr. kg	Part No.	Weight appr. kg	Part No.	Weight appr. kg	Part No.	Weight appr. kg	Part No.
1000 mm	4.1	KT9601110	6.4	KT9601120	13.2	KT9601130	17	KT9601140
2000 mm	8.2	KT9601210	12.8	KT9601220	26.4	KT9601230	34	KT9601240
3000 mm	12.3	KT9601310	19.2	KT9601320	39.6	KT9601330	51	KT9601340
4000 mm	16.4	KT9601410	25.6	KT9601420	52.8	KT9601430	68	KT9601440
5000 mm	20.5	KT9601510	32.0	KT9601520	66.0	KT9601530	85	KT9601540
6000 mm	—	—	38.4	KT9601620	79.2	KT9601630	102	KT9601640
7000 mm	—	—	—	—	92.4	KT9601730	119	KT9601740

1. KH-II-S Crane girder

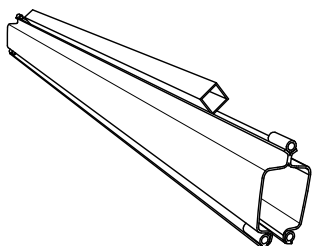
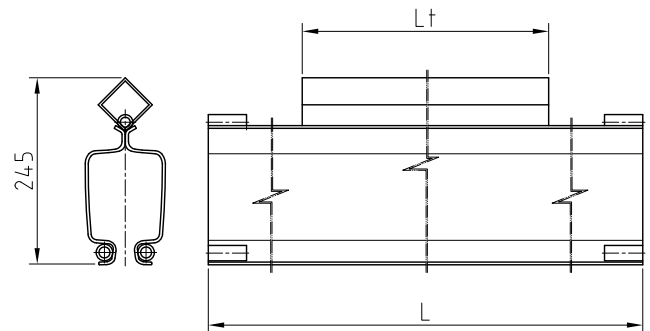

Length L (mm)	Length Lt (mm)	Weight (kg)	Part no.
4000	2000	74.8 kg	KT9601441
5000	3000	95.2 kg	KT9601541
6000	4500	117.3kg	KT9601641
6000	5400	120.4 kg	KT9601642
7000	5000	136.0 kg	KT9601741
7000	6000	139.4 kg	KT9601742

2. Joint bolt set

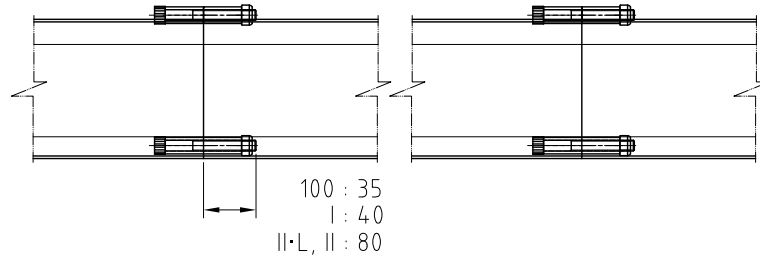
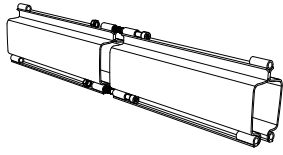

KH-100		KH-I		KH-II·L		KH-II		KH-R5	
Weight appr. kg	Part No.	Weight appr. kg	Part No.	Weight appr. kg	Part No.	Weight appr. kg	Part No.	Weight appr. kg	Part No.
0.05	KT9602010	0.1	KT9602020	0.44	KT9602030	0.44	KT9602040	0.44	KT9602040

4. Curved track section

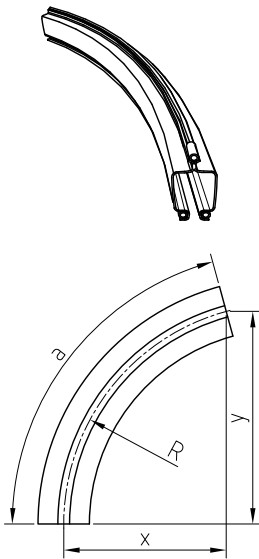

	Angle a	Dimension(mm)		Weight approx. kg	Part No.
		X	Y		
KH-I R=750	30°	100	375	2.5	KT9604120
	60°	375	650	5.0	KT9604220
	90°	750	750	7.5	KT9604320
KH-I R=1000	30°	135	500	3.5	KT9604420
	60°	500	865	6.7	KT9604520
	90°	1000	1000	10.0	KT9604620
KH-II R=1500	10°	25	260	4.9	KT9604140
	15°	50	390	7.1	KT9604240
	30°	200	750	13.7	KT9604340
	45°	440	1060	20.3	KT9604440
	60°	750	1300	26.9	KT9604540
	90°	1500	1500	36.5	KT9604640

6. Internal buffer stop

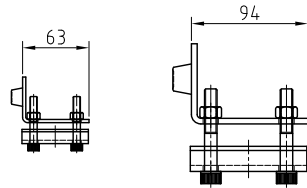
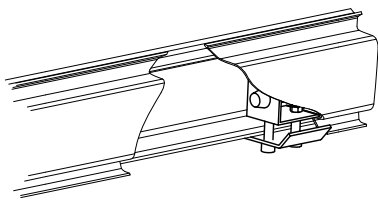

KH-100, KH-I KH-II·L, KH-II

Item no.	Weight appr. kg	Part No.	Section category
06	0.40	KT9606020	KH-100, KH-I
	0.80	KT9606040	KH-II·L, KH-II

7. End cap with buffer

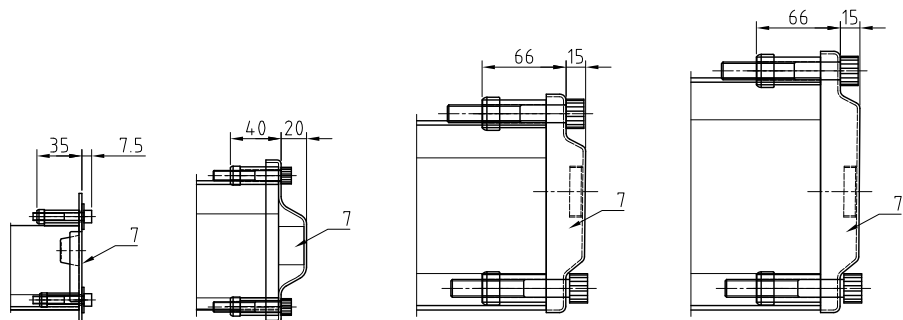
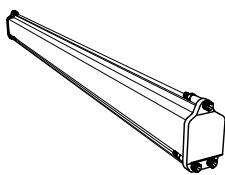

KH-100		KH-I		KH-II·L		KH-II		KH-R5	
Weight appr. kg	Part No.	Weight appr. kg	Part No.	Weight appr. kg	Part No.	Weight appr. kg	Part No.	Weight appr. kg	Part No.
0.1	KT9607010	0.1	KT9607020	0.44	KT9607030	0.44	KT9607040	0.44	KT9607040

Upper suspension assembly KH-I, II · L, II

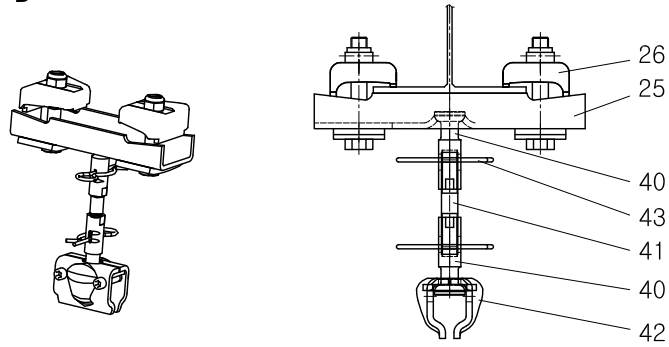

Suspension fitting

Item no.	Suspension fitting, vertical	Weight appr. kg	Part No.	KH-100 Qty./susp.	KH-I Qty./susp.	Weight appr. kg	Part No.	KH-II-L Qty./susp.	KH-II Qty./susp.
25	Upper suspension bracket A	0.65	KT9625120	1	1	1.20	KT9625140	1	1
	Upper suspension bracket B	0.85	KT9625220			1.40	KT9625240		
	Upper suspension bracket C	1.20	KT9625320			1.80	KT9625340		
26	Upper suspension Clamp	0.20	KT9626020	2	2	1.00	KT9626040	2	2
40	Ball head suspension rod	0.08	KT9640020	2	2	0.15	KT9640040	2	2
41	suspension rod $h_1=80\text{mm}$	0.07	KT9641120	1	1	0.18	KT9641540	1	1
	suspension rod $h_1=100\text{mm}$	—	—			0.22	KT9641140		
	suspension rod $h_1=300\text{mm}$	0.18	KT9641220			0.53	KT9641240		
	suspension rod $h_1=600\text{mm}$	0.33	KT9641320			1.01	KT9641340		
	suspension rod $h_1=1000\text{mm}$	0.53	KT9641420			1.64	KT9641440		
42	Track suspension clamp	0.65	KT9642010	1	—	1.20	KT9642040	1	1
		0.85	KT9642020	—	1				
43	Spring clip	0.01	KT9643020	2	2	0.02	KT9643040	2	2

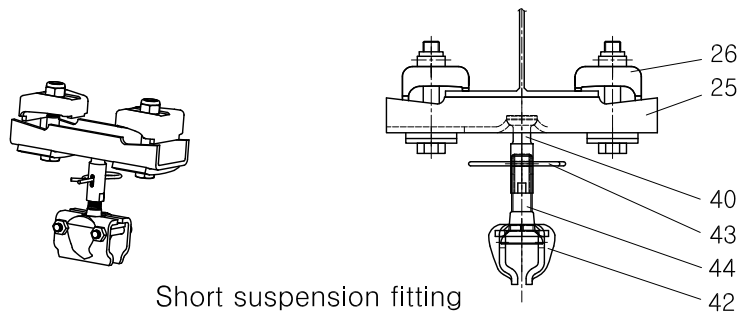

Short suspension fitting

Item no.	Suspension fitting, vertical	Weight appr. kg	Part No.	KH-100 Qty./susp.	KH-I Qty./susp.	Weight appr. kg	Part No.	KH-II-L Qty./susp.	KH-II Qty./susp.
25	Upper suspension bracket A	0.65	KT9625120	1	1	1.20	KT9625140	1	1
	Upper suspension bracket B	0.85	KT9625220			1.40	KT9625240		
	Upper suspension bracket C	1.20	KT9625320			1.80	KT9625340		
26	Upper suspension Clamp	0.20	KT9626020	2	2	1.00	KT9626040	2	2
40	Ball head suspension rod	0.08	KT9640020	1	1	0.15	KT9640040	1	1
42	Track suspension clamp	0.65	KT9642010	1	—	1.20	KT9642040	1	1
		0.85	KT9642020	—	1				
43	Spring clip	0.01	KT9643020	1	1	0.02	KT9643040	1	1
44	Ball head bolt	0.045	KT9644020	1	1	0.11	KT9644040	1	1

25. Upper suspension bracket

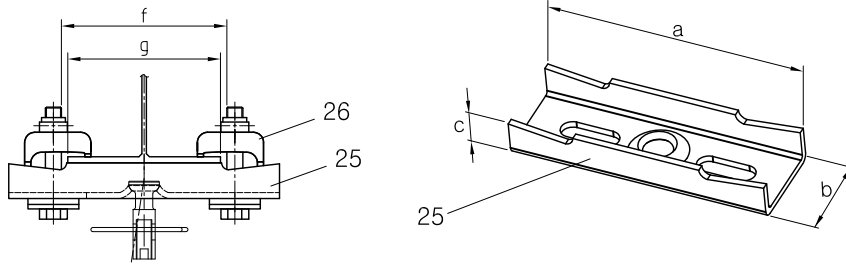

Item no.	Suspension fitting, vertical	Weight appr. kg	Part No.	Dimensions (mm)				Beam size g	Section category
				a	b	c	f		
25	Upper suspension bracket A	0.65	KT9625120	200	70	27	74-151	75,100,125	KH-100, KH-I
	Upper suspension bracket B	0.85	KT9625220	267	70	25	130-207	125,150,175	
	Upper suspension bracket C	1.20	KT9625320	316	70	27	172-250	175,200	
	Upper suspension bracket A	1.20	KT9625140	220	75	34	68-136	75,100,125	KH-II-L, KH-II
	Upper suspension bracket B	1.40	KT9625240	260	75	34	137-205	125,150,175	
	Upper suspension bracket C	1.80	KT9625340	316	75	36	164-230	175,200	

26. Upper suspension clamp

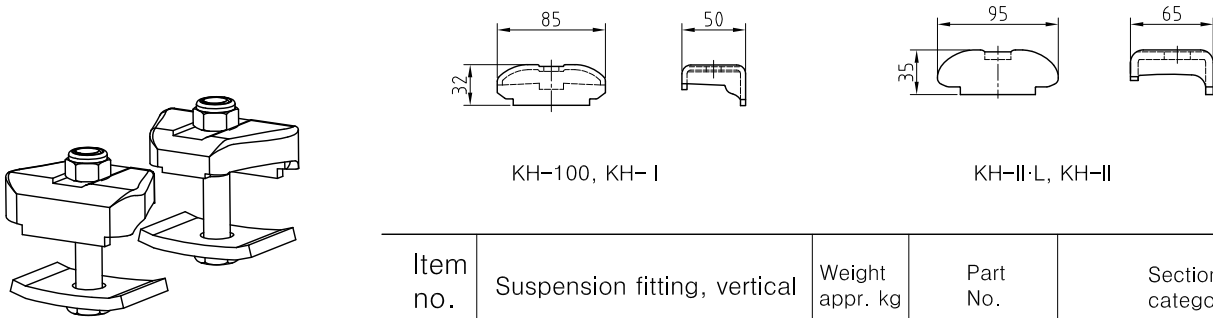

Item no.	Suspension fitting, vertical	Weight appr. kg	Part No.	Section category
26	Upper suspension clamp	0.20	KT9626020	KH-100, KH-I
		1.00	KT9626040	KH-II-L, KH-II

40. Ball head suspension rod

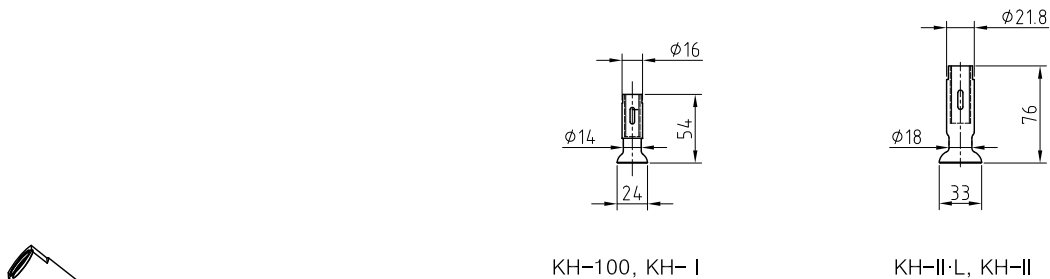

Item no.	Suspension fitting, vertical	Weight appr. kg	Part No.	Section category
40	Ball head suspension rod	0.08	KT9640020	KH-100, KH-I
		0.15	KT9640040	KH-II-L, KH-II

41. Suspension rod

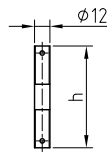
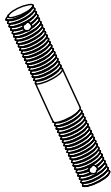

KH-100, KH- I

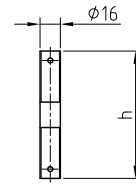

KH-II-L, KH-II

Item no.	Suspension fitting, vertical	h (mm)	KH-100, KH- I		KH-II-L, KH-II	
			Weight appr. kg	Part No.	Weight appr. kg	Part No.
41	Suspension rod	80	0.07	KT9641120	0.18	KT9641540
		100			0.22	KT9641140
		300	0.18	KT9641220	0.53	KT9641240
		600	0.33	KT9641320	1.01	KT9641340
		1,000	0.53	KT9641420	1.64	KT9641440

42. Track suspension clamp

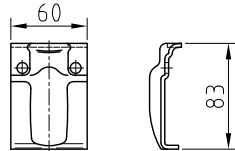
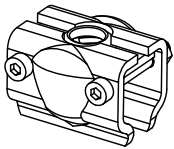

KH-100

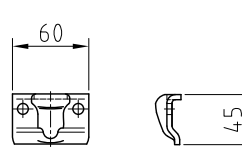

KH-I

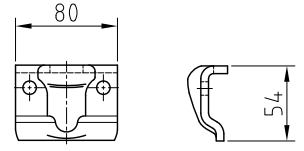

KH-II

Item no.	Suspension fitting, vertical	Weight appr. kg	Part No.	Section category
42	Track suspension clamp	0.30	KT9642010	KH-100
		0.20	KT9642020	KH- I
		0.80	KT9642040	KH-II-L, KH-II

43. Spring clip

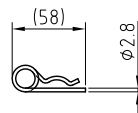
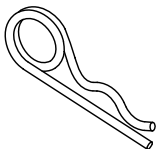

KH-100, KH- I

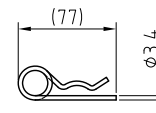

KH-II-L, KH-II

Item no.	Suspension fitting, vertical	Weight appr. kg	Part No.	Section category
43	Spring clip	0.01	KT9643020	KH-100, KH- I
		0.02	KT9643040	KH-II-L, KH-II

44. Ball head bolt

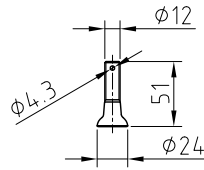
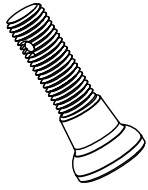

KH-100, KH- I

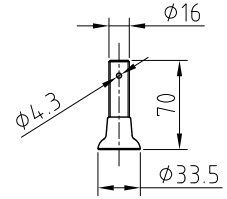

KH-II-L, KH-II

Item no.	Suspension fitting, vertical	Weight appr. kg	Part No.	Section category
43	Ball head bolt	0.05	KT9644020	KH-100, KH- I
		0.11	KT9644040	KH-II-L, KH-II

55. Trolley

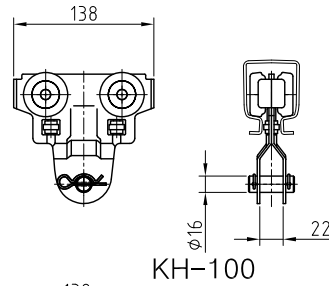
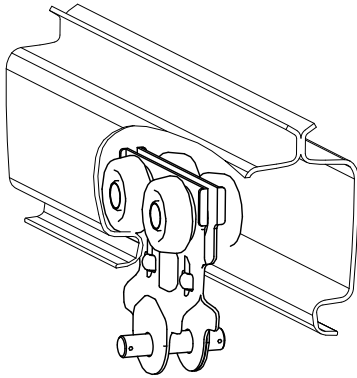

KH-100

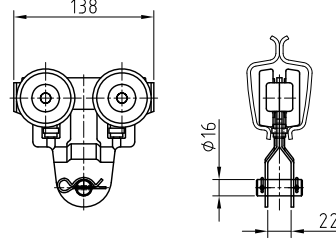

KH-I

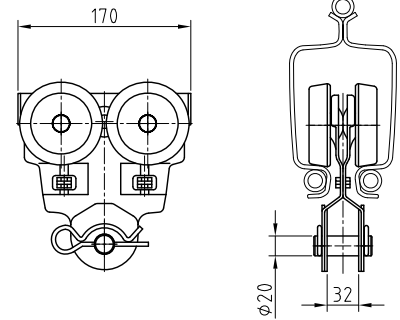

KH-II-L, II

KH-100			KH-I			KH-II-L, II		
Max. load kg	Weight appr. kg	Part No.	Max. load kg	Weight appr. kg	Part No.	Max. load kg	Weight appr. kg	Part No.
100	0.8	KT9655010	300	0.85	KT9655020	600	1.95	KT9655040

57. Load bar

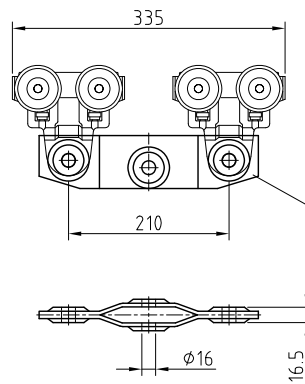
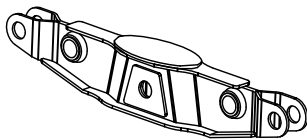

KH-100, I

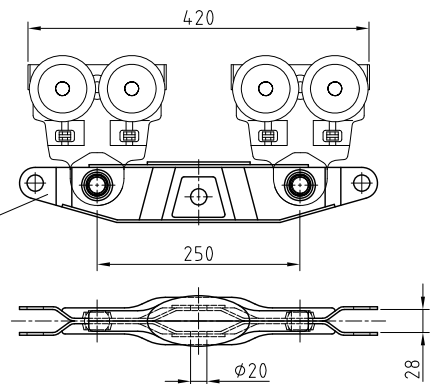

KH-II-L, II

KH-100			KH-I			KH-II-L, II		
Max. load kg	Weight appr. kg	Part No.	Max. load kg	Weight appr. kg	Part No.	Max. load kg	Weight appr. kg	Part No.
200	1.39	KT9657020	400	1.39	KT9657020	1200	2.1	KT9657040

69. Trolley for friction wheel
70. Friction wheel travel drive

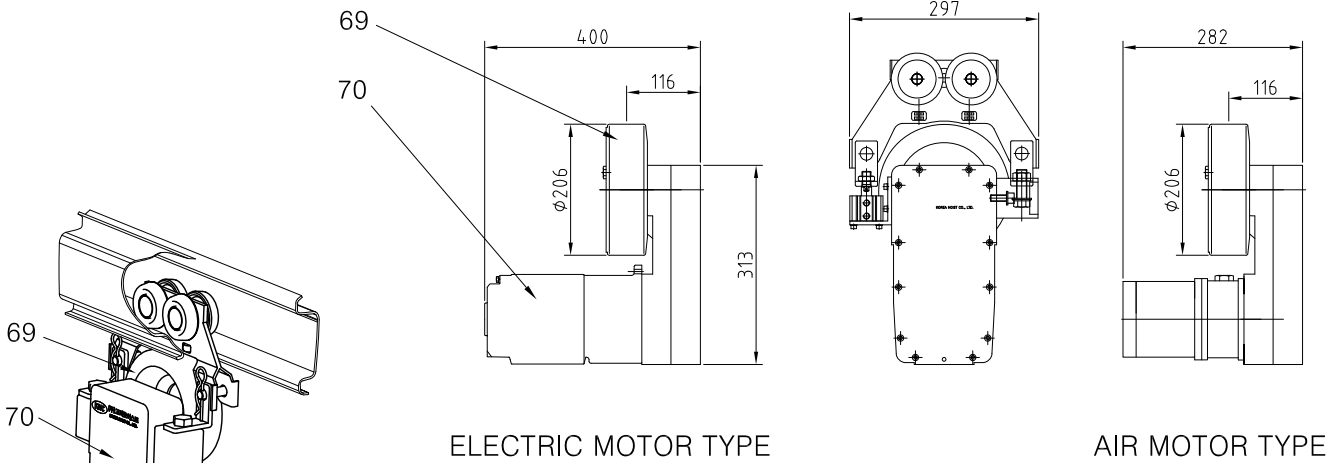

ELECTRIC MOTOR TYPE

AIR MOTOR TYPE

ELECTRIC MOTOR		AIR MOTOR	
Rated Voltage	220 V, 380 V, 440 V	Rated Air Pressure	6 kg/cm ²
Rated Frequency	60 Hz (50 Hz)	Rated Power	0.5 kW X 2P
Rated Power	0.2kWx2P / 0.05kWx8P	Rated Speed	1700 RPM
Full Load Speed	880(733) RPM / 3500(2915) RPM	Free Speed	2800 RPM
Traversing speed	6.24(5.2) m/min / 24(20) m/min	Traversing speed	0-18m/min

75. Crane suspension eye

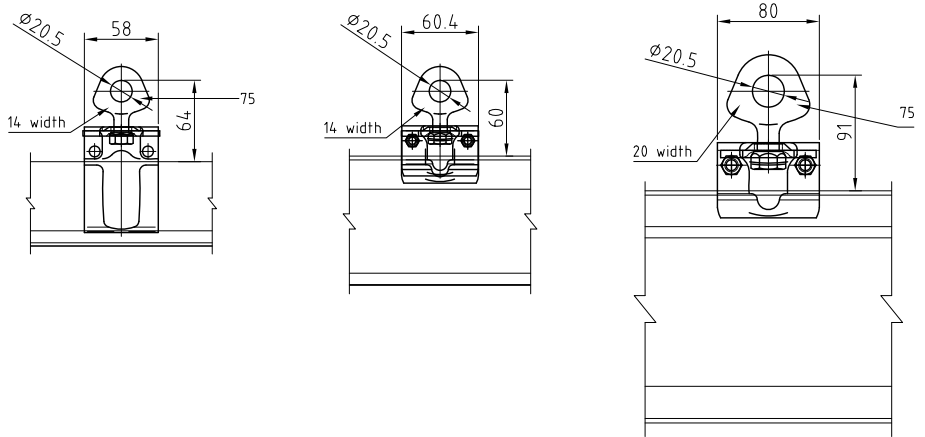
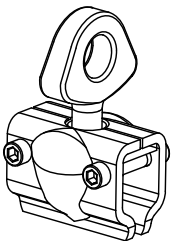

KH-100

KH-I

KH-II L, II

KH-100			KH-I			KH-II L, II		
Max. load kg	Weight appr. kg	Part No.	Max. load kg	Weight appr. kg	Part No.	Max. load kg	Weight appr. kg	Part No.
400	1.1	KT9675010	600	0.9	KT9675020	1400	2.0	KT9675040

78. Crab frame

KH-I : KT9678020

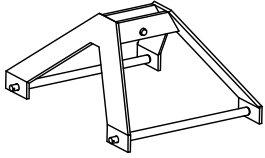
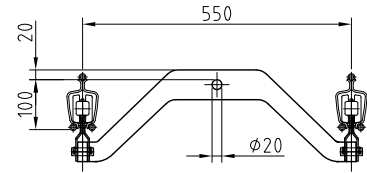
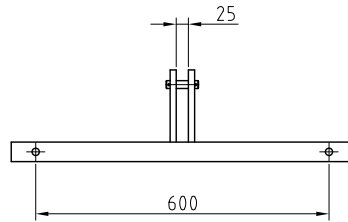

KH-II·L, II : KT9678040

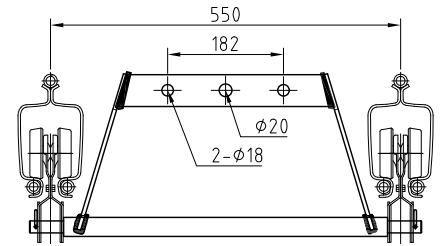
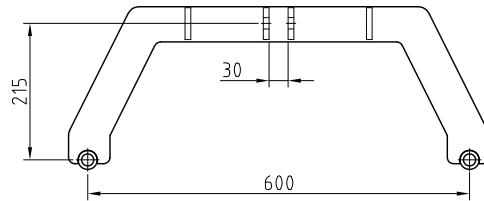

79. Bracing Frame

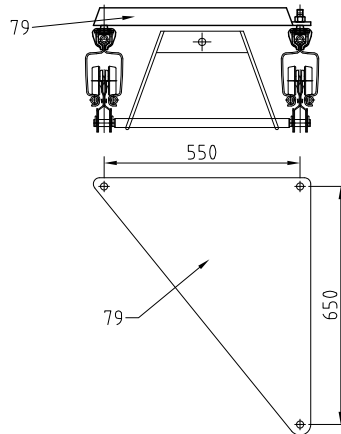
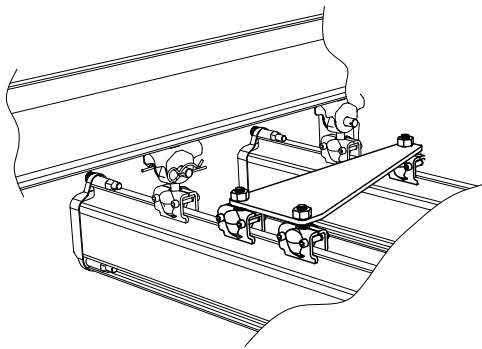

KH-I, KH-II·L, II

Weight appr. kg	Part No.
11.00	KT9679040

83. Cable clamp

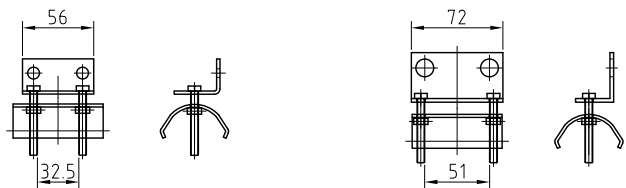
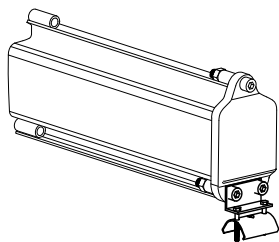

KH-I			KH-II·L, II		
Max. load kg	Weight appr. kg	Part No.	Max. load kg	Weight appr. kg	Part No.
40	0.25	KT9683020	40	0.25	KT9683040

85. Cable slider (Plastic)

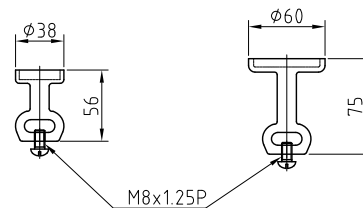

Item no.	Suspension fitting, vertical	Weight appr. kg	Part No.	Section category
85	Cable slider	0.03	KT9685020	KH-100, KH-I
		0.04	KT9685040	KH-II·L, KH-II

86. Cable trolley (steel)

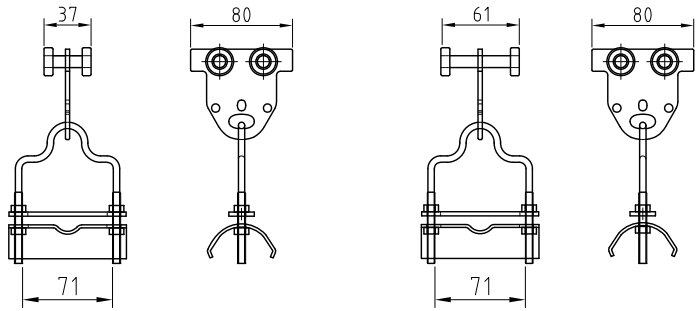
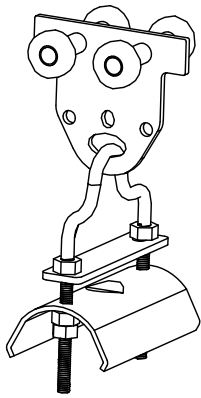

KH-100, I			KH-II·L, II		
Max. load kg	Weight appr. kg	Part No.	Max. load kg	Weight appr. kg	Part No.
40	0.3	KT9686020	40	0.4	KT9686040

87. Cable trolley (Plastic)

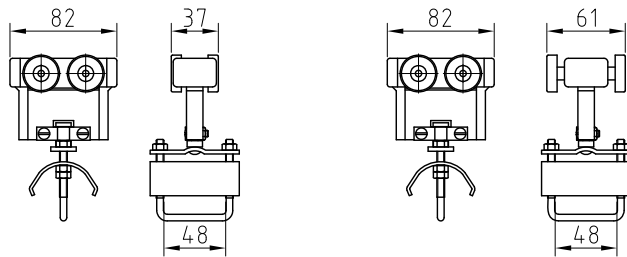
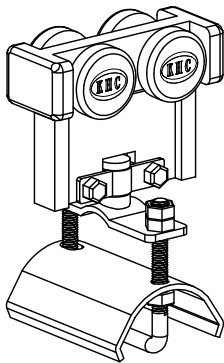

KH-100, I			KH-II·L, II		
Max. load kg	Weight appr. kg	Part No.	Max. load kg	Weight appr. kg	Part No.
30	0.28	KT9687020	30	0.3	KT9687040

Track suspension fittings

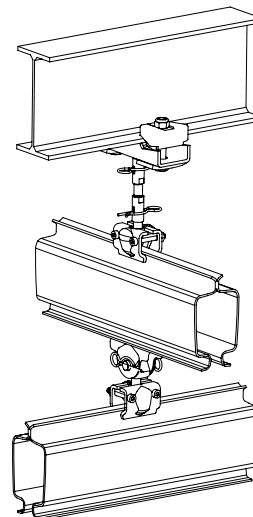
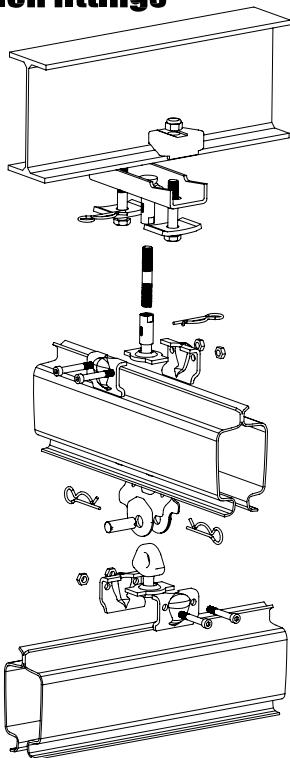

* The content of the Manual can be changed without prior notice according to the performance enhance.



(주)고려호이스트
KOREA HOIST CO., LTD.

All rights reserved.
Copy rights.

PRINTED IN KOREA 08/10/13

Block 3Ba 630, Shiwha Ind. Complex,
Jungwang -Dong, Sihung City,
Kyunggi-Do, Korea

Phone:(82) 31-431-6030

Fax:(82) 31-499-3630

<http://www.koreahoist.co.kr>

E-Mail:koreahoist@koreahoist.co.kr

Cornerstone Material Handling Inc.

258 Prospect Street,

P.P.Box 519,

St. George, ON N0E 1N0

Phone:(877) 611-2644, (519) 448-3344

Fax: (519) 448-4514

E-Mail: cmhi@cornerstonematerialhandling.com